

CAP PRESS



Operator's Manual

Heat Transfer Equipment

IMPORTANT SAFETY INSTRUCTIONS

WHEN USING YOUR APPLIANCE, BASIC PRE-CAUTIONS SHOULD ALWAYS BE FOLLOWED, INCLUDING THE FOLLOWING:

1. Read all instructions.
2. Use appliance only for its intended use.
3. To reduce the risk of electric shock, do not immerse the appliance in water or other liquids.
4. Never pull cord to disconnect from outlet, instead grasp plug and pull to disconnect.
5. Do not allow cord to touch hot surfaces, let appliance cool completely before putting away.
6. Do not operate appliance with a damaged cord, or if the appliance has been dropped or damaged. To reduce the risk of electric shock, do not disassemble or attempt to repair the appliance, take it to a qualified service person for examination and repair. Incorrect reassembly or repair could cause a risk of fire, electric shock, or injury to persons when the appliance is used.
7. Close supervision is necessary for any appliance being used by or near children. Do not leave appliance unattended while connected.
8. Burns could occur from touching hot metal parts.
9. To reduce the likelihood of circuit overload, do not operate another high voltage appliance on the same circuit.
10. If an extension cord is absolutely necessary, a 20 ampere rated cord should be used. Cords rated for less amperage may overheat, care should be taken to arrange the cord so that the cord cannot be pulled or tripped over.

SAVE THESE INSTRUCTIONS

TABLE OF CONTENTS

CAP PRESS PARTS LOCATION GUIDE.....	4
OPERATING INSTRUCTIONS.....	5-8
CAP PRESS ELECTRICAL SCHEMATIC.....	9

CAP PRESS PARTS LOCATION GUIDE

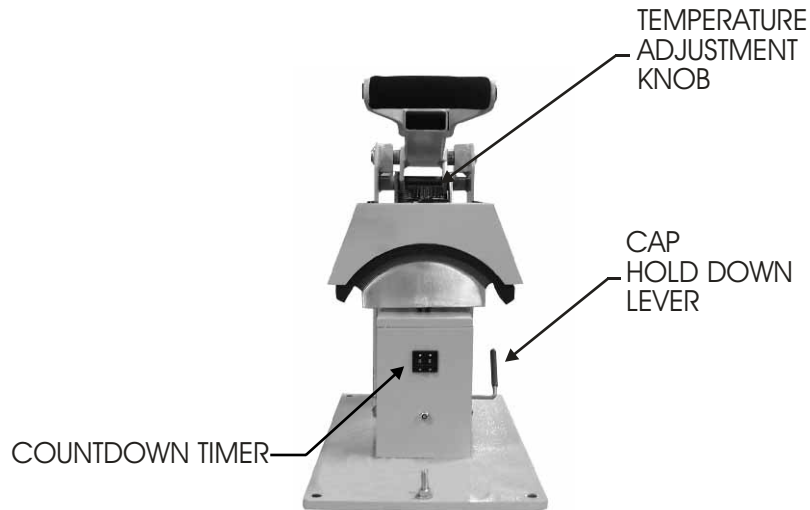

FRONT VIEW

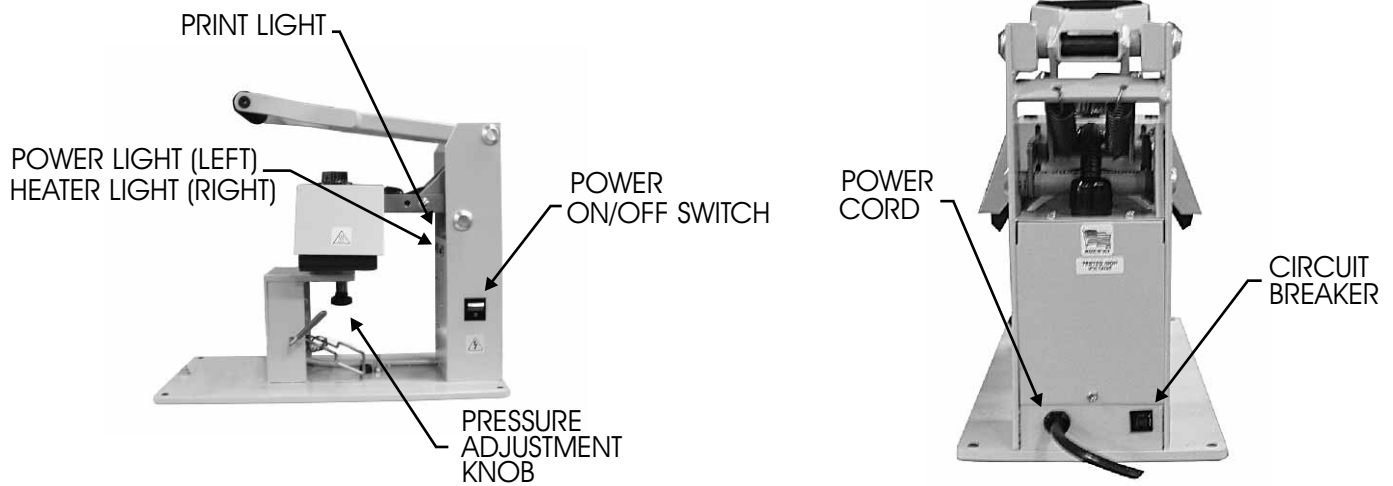

SIDE VIEW

REAR VIEW

Operating Instructions

CAP PRESS

The Operating Instructions are designed with you in mind. Carefully read and follow the step-by-step instructions for best results. If you experience any difficulty, carefully re-read the instructions and try again.

Step 1

CONNECT THE POWER CORD:

Connect the power cord into a properly grounded electrical outlet with a sufficient amperage rating.

120 Volt

Your CAP PRESS requires a full 4.5 amp grounded circuit for 120 volt operation.

240 Volt

Your CAP PRESS requires a full 2.5 amp grounded circuit for 240 volt operation.

Extension Cords, if used, should be as short as possible and not less than 12 gauge. Heavy duty cords are recommended.

Circuits that have under 15 amps or other high demand equipment or appliances (especially more than one heat seal machine) should not be used.

NOTE:

If the supply cord is damaged, it must be replaced by the manufacturer or its service agent or a similarly qualified person in order to avoid hazard.

CAUTION

FAILURE TO FOLLOW THESE INSTRUCTIONS WILL CAUSE:

1. Erratic controller functions.
2. Inaccurate displays and slow heat-up.
3. The circuit breaker to disengage.

Step 2 SWITCH THE SYSTEM ON

Locate the Power ON/OFF Switch on the press.

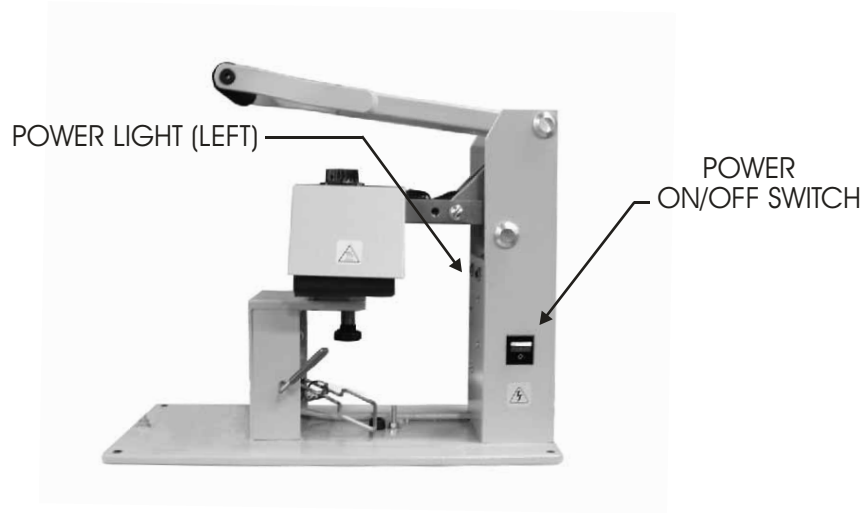

Step 3 ADJUST THE TEMPERATURE

Locate the Temperature Adjustment Knob on the press.

Adjust the temperature per application instruction.

NOTE: The Heater Light located on the right side of the control housing will continually cycle on and off once the machine has reached the designated temperature. During the initial warm-up of your press, the Heater Light will remain on. The machine will take approximately 15 minutes to arrive at its designated temperature.

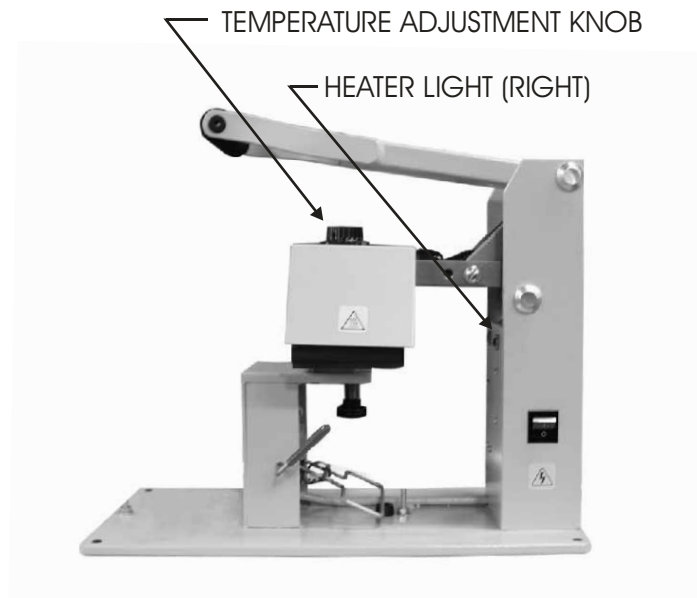

Step 4 ADJUST THE PRESSURE

The Pressure Adjustment Knob is located directly under the cap platen.

Adjust the pressure by turning the knob clockwise to increase pressure and counter clockwise to decrease pressure.

REMEMBER: To allow for the thickness of your garment when adjusting the pressure.

WARNING: STRUCTURAL DAMAGE CAUSED BY EXCESSIVE PRESSURE IS NOT COVERED UNDER THE LIMITED WARRANTY!

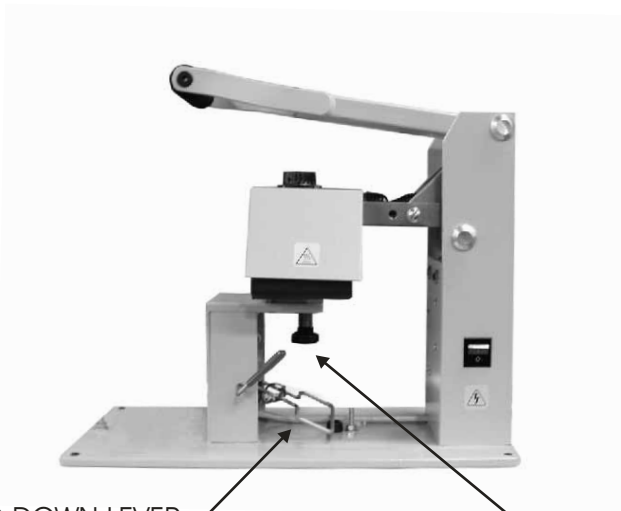

CAP HOLD DOWN LEVER

PRESSURE ADJUSTMENT KNOB

Step 5 LOADING THE CAP

Place Cap Hold Down in the “UP” position by lifting the end handle located just below the right side of the cap platen.

Position the cap by placing the face of the cap on the platen. Pull the rear of the cap down around the Cap Hold Down. Lower the Cap Hold Down Lever by pushing it away from the platen. At this time, make sure face of cap is well conformed to platen and visor board is even with the front of the platen.

Step 6 ADJUST THE TIME

Locate the Countdown Timer. Adjust the Timer by pressing the “-” Key to decrease and the “+” Key to increase the printing time. For example, 06 is 6 seconds. The Countdown Timer has a range from 01 to 99 seconds. The Timer will automatically reset after every print.

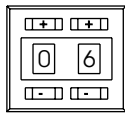

Enlarged Graphic
for Detail

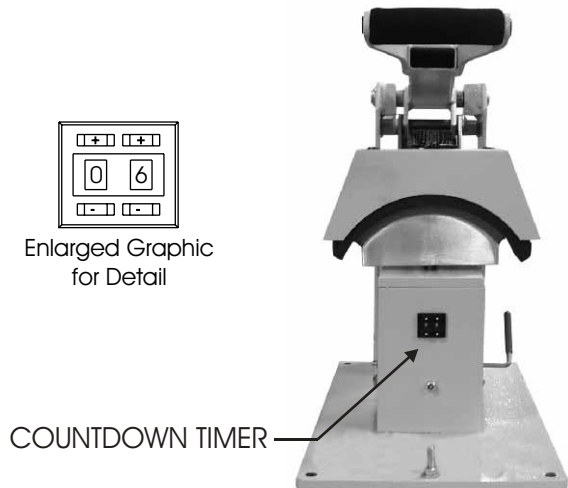

COUNTDOWN TIMER

PRINT LIGHT

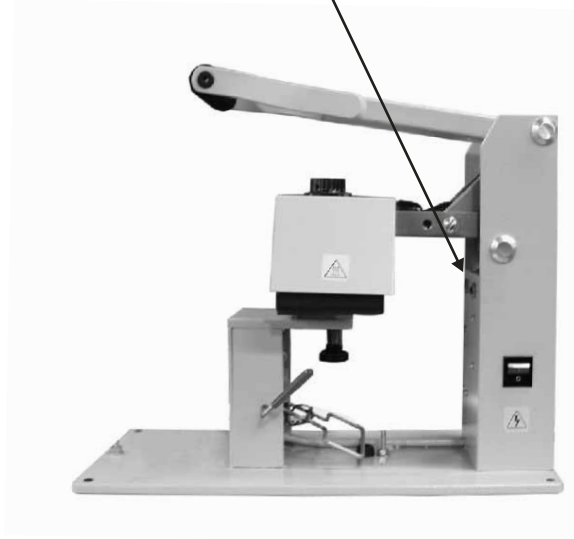

Step 7 PRINT

Once your equipment has reached the designated temperature, position the garment and application and proceed to press.

Lower and lock the heat platen into the press position. This procedure will start the automatic timing process.

When the Print Light illuminates and constant alarm sounds, lift the heat platen and proceed according to the application instructions.

CAP PRESS ELECTRICAL SCHEMATIC

