

AUTO OPEN SERIES
LOWRIDER

OPERATOR'S MANUAL



STAHL'S
Hotronix[®]

When using your heat press, basic precautions should always be followed, including the following:

1. Read all instructions.
2. Use heat press only for its intended use.
3. To reduce the risk of electric shock, do not immerse the heat press in water or other liquids.
4. Never pull cord to disconnect from outlet, instead grasp plug and pull to disconnect.
5. Do not allow cord to touch hot surfaces, allow heat press to cool completely before storing.
6. Do not operate heat press with a damaged cord or if the equipment has been dropped or damaged. To reduce the risk of electric shock, do not disassemble or attempt to repair the heat press. Take it to a qualified service person for examination and repair. Incorrect assembly or repair could increase the risk of fire, electric shock, or injury to persons when the equipment is used. Power supply cord must be disconnected before cleaning or servicing press.
7. This appliance is not intended for use by persons (including children) with reduced physical, sensory or mental capabilities, or lack of experience and knowledge, unless they have been given supervision or instruction concerning use of the appliance by a person responsible for their safety.
8. Close supervision is necessary for any heat press being used by or near children. Do not leave equipment unattended while connected.
9. To avoid burns, do not touch hot metal parts or the heated platen during use.
10. To reduce the likelihood of circuit overload, do not operate other high voltage equipment on the same circuit.
11. If an extension cord is necessary, then a 12GA/20AMP cord should be used. Cords rated for less amperage may overheat. Care should be taken to arrange the cord so that it cannot be pulled or tripped over.
12. Keep hands clear of the upper heat press platen during lock down as the pressure may cause injury.
13. Heat press should be placed on a sturdy, suitable stand at least 36"L x 24"W x 29"H.
14. Work area must be kept clean, tidy and free of obstructions.

Table Of Contents



Safety Instructions 2

Machine View 4

Operating Instructions 5-8

LED Display 5

Connecting the System 6

Start Up/Shut Down 6

Adjusting Settings 7-8

Electrical Schematic 9

Replacement Parts List 10-11

Contact 12

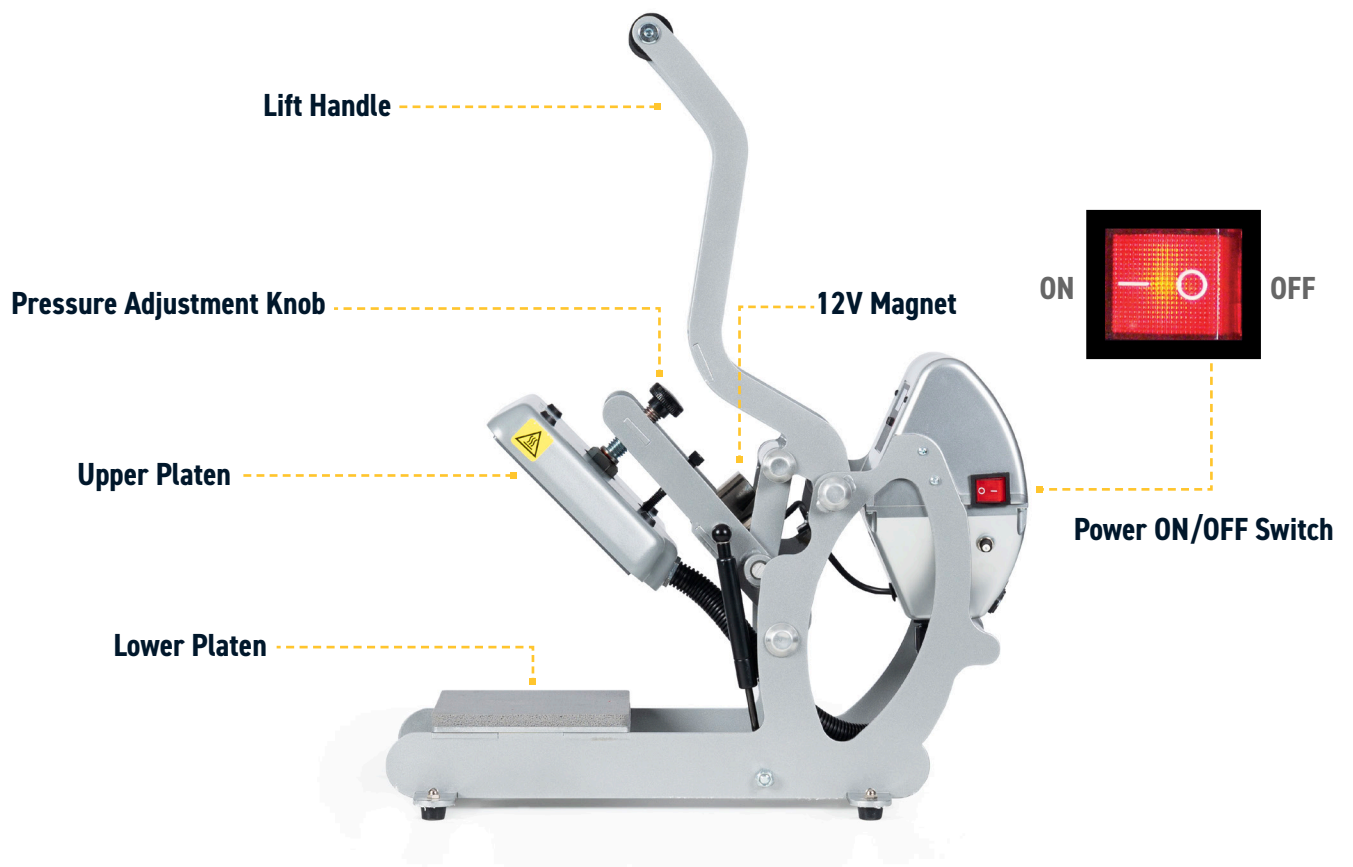

Operating Instructions

LED Display



HOTRONIX® LOWRIDER

Connecting the System

Connect the power cord into a properly grounded electrical outlet with a sufficient amperage rating (1.1).

Voltage

120 volt requires a fully dedicated 10-amp grounded circuit.

220 volt requires a fully dedicated 10-amp grounded circuit.

Extension cords should be as short as possible and not less than 12 gauge. Heavy duty cords are recommended.

Circuits with less than 10 amps or other high demand equipment or appliances (especially more than one heat press machine) plugged in, should not be used.

NOTE: If the supply cord is damaged, it must be replaced by the manufacturer, its service agent or a similarly qualified person in order to avoid hazard. Use SJT type, rated 300V for replacement.

CAUTION Failure to follow these instructions will cause:

1. Erratic controller functions.
2. Inaccurate displays and slow heat-up.
3. The circuit breaker to disengage.

Start Up/Shut Down

Locate the packaging bolt on top of press and remove prior to turning on or operating (2.1).

Locate the Power ON/OFF Switch on the side of the press, then turn the Power Switch ON (2.2).

NOTE: The LowRider Press is equipped with an Auto Sleep Mode. When the machine is inactive for a period of two hours, it will enter an energy saving sleep mode. To restore to normal operating mode, press any button on the display panel and allow the heat press to return to the target temperature.

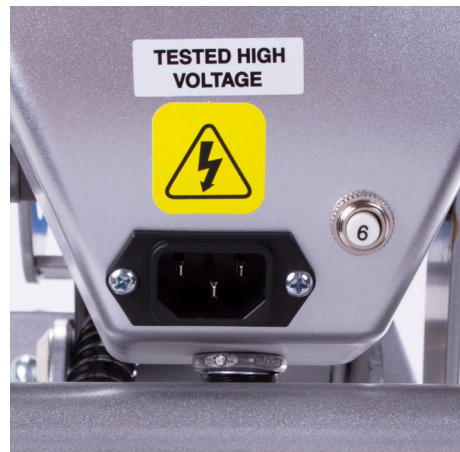

1.1



2.1



2.2

Operating Instructions

Adjusting Settings

Adjust Temperature

Press the Mode Select button in the center of the Control Panel.
The (SET) and (TEMP) lights located next to the display will illuminate.

Press the (+) or (-) button to raise or lower the temperature setting.
The temperature can be set from 176°F (79°C) to 430°F (220°C).
The LED Display will show changes as you make them.

Adjust Time

Your heat press has two time settings that will allow you to set different times when a two-hit application is required. For single-hit applications, simply set both time settings the same.

Once the temperature is adjusted, press the Mode Select button again to advance to Time #1 Mode. The (SET) and (TIME) lights will illuminate, indicating you are in Time #1 Mode.

Once you have Time #1 set, push the Mode Select button again to advance to Time #2 Mode. All three red LED lights will illuminate indicating you are in Time #2 Mode. Select the desired time and push the Mode Select button again to exit time settings. All lights will be off and the press will return to PRINT mode.

NOTE:

- Press the Mode Select button ONCE to advance to Adjust Temperature Mode.
- Press the Mode Select button A SECOND TIME to advance to Time #1 Mode.
- Press the Mode Select button A THIRD TIME to advance to Time #2 Mode.
- Press the Mode Select button A FOURTH TIME to return to Heat Up/Operating Mode.

HOTRONIX® LOWRIDER

Adjust Pressure

Turn knob clockwise to increase pressure and counterclockwise to decrease pressure.

PRESSURE READOUT

A visual Pressure Readout is located on the lower right side of the LED Display.

When the handle is locked into the PRINT position, a pressure number between 0-9 will be displayed.

0 indicates no pressure and 9 indicates very heavy pressure.

Remember to allow for the thickness of your cap when adjusting the pressure.

1 - 3 = Light Pressure

4 - 7 = Medium Pressure

8 - 9 = Heavy Pressure

WARNING: Structural damage caused by excessive pressure is not covered under the limited warranty!

Pressing

Once your equipment has reached the designated temperature:

- Position the garment and design
- Lower and lock the heat platen into press position
- The automatic timing process will begin

The timer will automatically count down and lift the heat platen into the UP position when the print cycle is complete.

Note: Please be aware after time is complete, gas shocks will automatically release the platen into the UP position.



Electrical Schematic

US 120V/240V VERSIONS

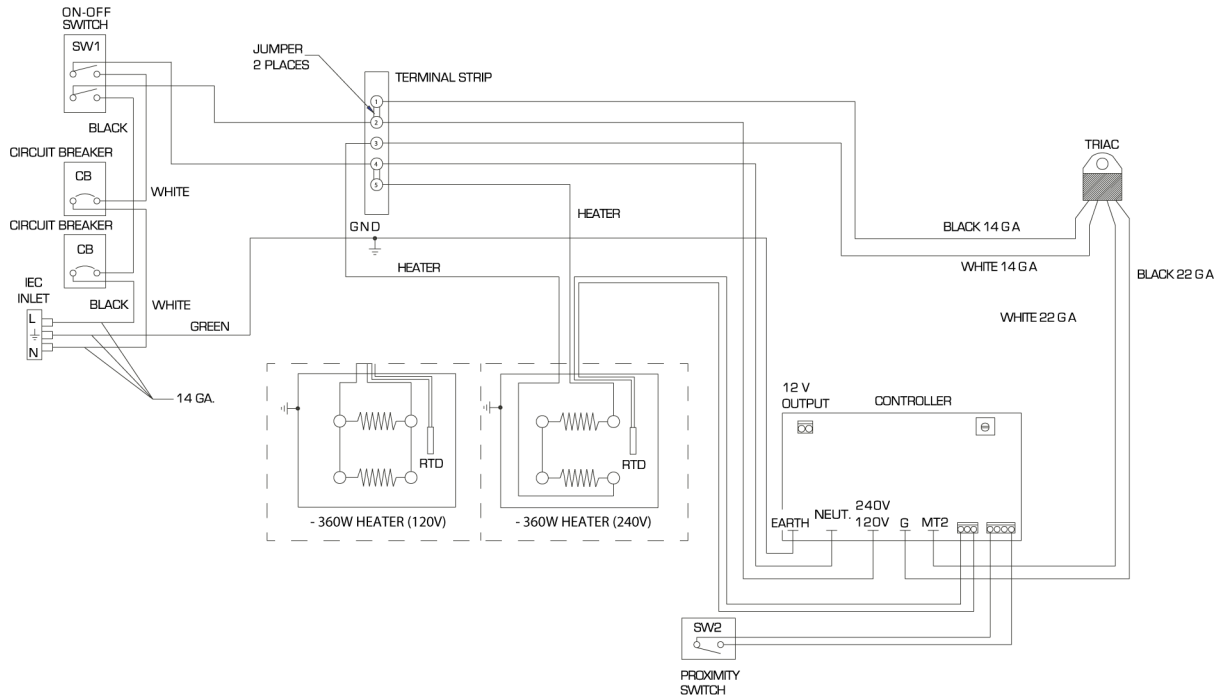

CE 230V VERSION

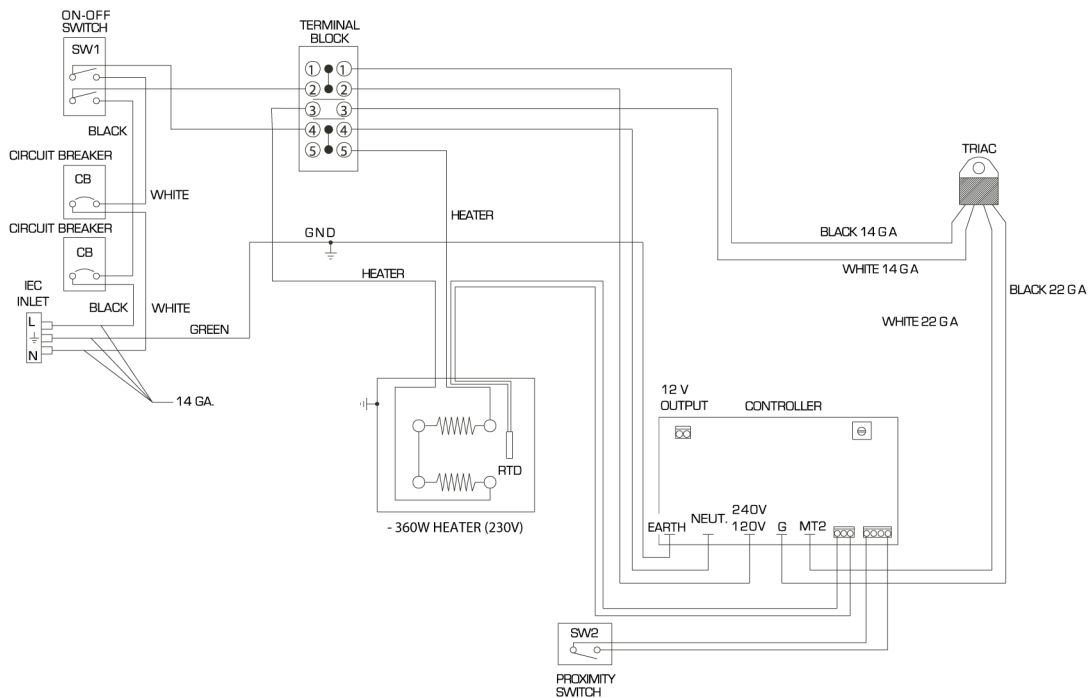

ITEM #	PART NAME	PART #	QTY
1	Control Housing, STX	4-1172-S	1
3	Controller Overlay, STX	1-2018-1	1
4	Grommet, 9/32" ID 3/8" OD	1-2105	2
5	Screw, Sheet Metal #6 x 1/2"	3-1011-235	6
6	Nut, #6-32 Hex with Lockwasher	2-1006-50	9
7	Screw, Pan Phillips #4-40 x 1"	3-1011-130	2
8	Power Inlet	1-1759	1
9	Power Switch	1-2087	1
10	Screw, Machine #6-32 x 1/2"	3-1011-19	7
11	Screw, Machine #6-32 x 1/4"	3-1011-25	7
12	Conduit Fitting, 1/2" Topaz Straight Twist-On	1-1353	2
13	Controller Kit, STX	Kit 3-6945	1
14	Nut, #4-40 with Tooth Washer	2-1006-51	8
15	Controller Bracket, STX MAXX	2-1661	1
16	TRIAC	2-1675	1
17	Screw, Machine #4-40 x 3/8"	3-1011-22	6
18	Terminal Block, 5 Contact High Voltage	1-1290	1
20	Proximity Switch	1-1211	1
21	Circuit Breaker 5A (CAP 6x6)	1-2317	2
24	Handle Assembly, STX LowRider	Kit 3-6910-2	1
28	Magnet Bracket, STX6 & Cap	1-2085-3	1
29	Proximity Magnet	1-1219	1
30	Steel Pin, 1/2" x 7-1/4"	2-1055-16	1
31	Washer, 1/2" Nylon	1-1048-3	6
32	Hub Cap 1/2"	1-1107-1	6
33	Steel Pin, 1/2" x 5-7/8"	2-1055-9	1
34	JCN - NUT	2-1006-2	2
35	All Thread Pin	1-1042-1	1
36	PVC Spacer, 1/2" x 5"	1-1049-11	1
37	Foam Grip, Black	1-1540	1
38	Shipping Bolt (Thumb Screw), 1/4"-20 x 1/2"	3-1011-232	1
40	Pressure Link Weldment, LowRider	Kit 3-6909-1	1
41	Base, STX LowRider	Kit 3-6907-2	1
47	Screw, Button Socket Head #10-32 x 1/2"	3-1011-164	4
48	Rubber Foot	1-1256	4
49	Acorn Nut 10-32	3-1011-182	4
50	Nut, Hex Nylok 5/16"-18	2-1006-20	2

ITEM #	PART NAME	PART #	QTY
51	Ball Stud 10mm	1-1939	2
52	Screw, Pan Phillips #6-32 x 3/4"	3-1011-252	1
53	Wing Nut, 5/16"-18	2-1006-97	1
55	Gas Spring, LowRider	1-2254	1
57	Lower Platen, LowRider 6 x 6	Kit 3-6911-1	1
60	Silicone Pad, 6 x 6 Gray	1-2150	1
61	Lower Platen, LowRider 4in Round	Kit 3-6963	1
62	Silicone Pad, 4in Round Gray	1-2405	1
63	Lower Platen, LowRider Y	Kit 3-3962	1
64	Silicone Pad, LowRider Y Gray	1-2406	1
66	Heater Arm Assembly, LowRider	Kit 3-6912-1	1
70	Steel Pin, 1/2" x 6.45"	2-1055-26	1
71	Shaft Collar, STX6LR Long	1-2441	1
72	Steel Pin, 1/2" x 5.10"	2-1055-28	1
73	Shaft Collar, STX6LR	1-2432	1
74	Electromagnet	1-1945-1	1
75	Silicone Pad, 5/16" ID x 1-3/4" OD x 1/4" T	1-2104	1
76	Washer, 5/16" SS	2-1006-46	1
77	Screw, Shoulder 5/16" x 1/2" w/ 1/4"-20 Thread	3-1011-233	1
78	Heat Platen 6 x 6, 120V	3-1334	1
79	Insulation, 6 x 6	1-2327	1
80	Heat Platen Cover, 6 x 6	2-1662	1
81	Adjustment Spindle, LowRider	2-2147-A	1
82	Knob, Black Plastic 3/8"-16	1-1095	1
85	Screw, Socket Head Cap 5/16"-18 x 3"	3-1011-227	1
86	Washer, Plastic Finishing	1-1063	4
87	Screw, Flat Head Phillips #10-24 x 7/16"	3-1011-217	4
88	Plug, 9/16" Round Steel	1-2127	1
89	Temperature Probe	1-1272-1	1
90	Thermostat Disc	1-2076	1
91	Screw, SS Sheet Metal #4 X 1/4"	3-1011-98	2
93	Screw, SS Phillips #8-32 X 1/4"	3-1011-87	1
94	Conduit, STX LowRider, 12"	1-1048-2	1
200	120V Locking Power Cord	2-1671	1
200	220V Power Cord	1-2186	1
200	230V European Locking Power Cord	2-1672	1

Parts Location Guide

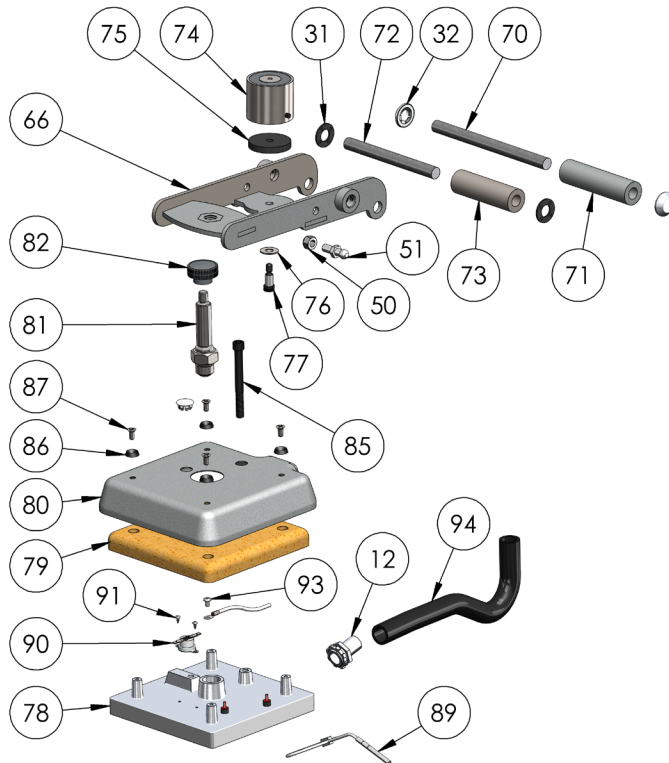
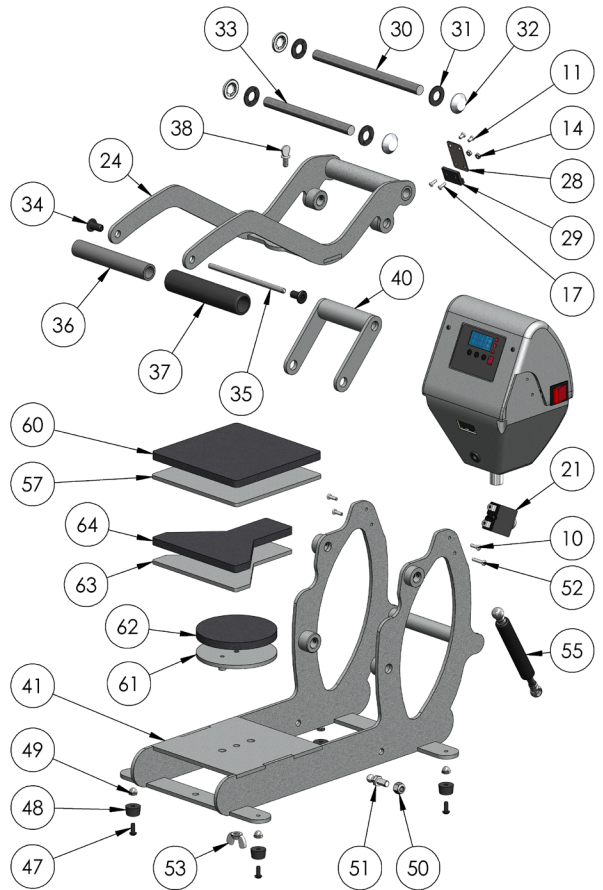
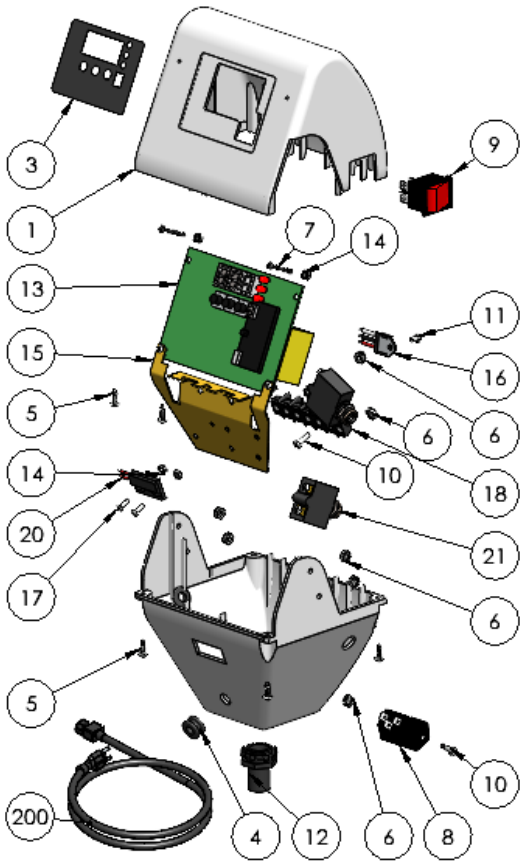

CONTACT US

STAHL'S Hotronix®

One Industrial Park
Carmichaels, PA 15320
U.S.A.

Technical Support

hotronix.com/support

Customer Service

customerservice@hotronix.com

Replacement Parts

hotronix.com/locationspart

Web

hotronix.com

