

DIGITAL CLAM

MAXX[®] 250 PRESS

OPERATOR'S MANUAL



Available models: MAXX[®] 250 Clam
11" x 15", 16" x 16", 16" x 20" (shown)

STAHL'S
Hotronix[®]

When using your heat press, basic precautions should always be followed, including the following:

1. Read all instructions.
2. Use heat press only for its intended use.
3. To reduce the risk of electric shock, do not immerse the heat press in water or other liquids.
4. Never pull cord to disconnect from outlet, instead grasp plug and pull to disconnect.
5. Do not allow cord to touch hot surfaces, allow heat press to cool completely before storing.
6. Do not operate heat press with a damaged cord or if the equipment has been dropped or damaged. To reduce the risk of electric shock, do not disassemble or attempt to repair the heat press. Take it to a qualified service person for examination and repair. Incorrect assembly or repair could increase the risk of fire, electric shock, or injury to persons when the equipment is used. Power supply cord must be disconnected before cleaning or servicing press.
7. This appliance is not intended for use by persons (including children) with reduced physical, sensory or mental capabilities, or lack of experience and knowledge, unless they have been given supervision or instruction concerning use of the appliance by a person responsible for their safety.
8. Close supervision is necessary for any heat press being used by or near children. Do not leave equipment unattended while connected.
9. To avoid burns, do not touch hot metal parts or the heated platen during use.
10. To reduce the likelihood of circuit overload, do not operate other high voltage equipment on the same circuit.
11. If an extension cord is necessary, then a 10GA/20AMP rated cord should be used. Cords rated for less amperage may overheat. Care should be taken to arrange the cord so that it cannot be pulled or tripped over.
12. Keep hands clear of the upper heat press platen during lock down as the pressure may cause injury.
13. Heat press should be placed on a sturdy, suitable stand at least 36"L x 24"W x 29"H.
14. Work area must be kept clean, tidy and free of obstructions.

Product Warranty Registration

Log onto www.Hottronix.com/registration
You must provide the Hottronix® heat press serial number and model information.

Table Of Contents

Safety Instructions	2
Machine View	4
Control Panel Guide	5
Operating Instructions	6-8
Connecting the System	6
Start Up/Shut Down	6
Adjusting Temperature	7
Adjusting Time	7
Adjusting Pressure	8
Printing/Pressing	8
Electrical Schematic	9
Parts Location Guide	10
Replacement Parts List	11
Contact	12



HOTRONIX® MAXX® 250 PRESS

Machine Views

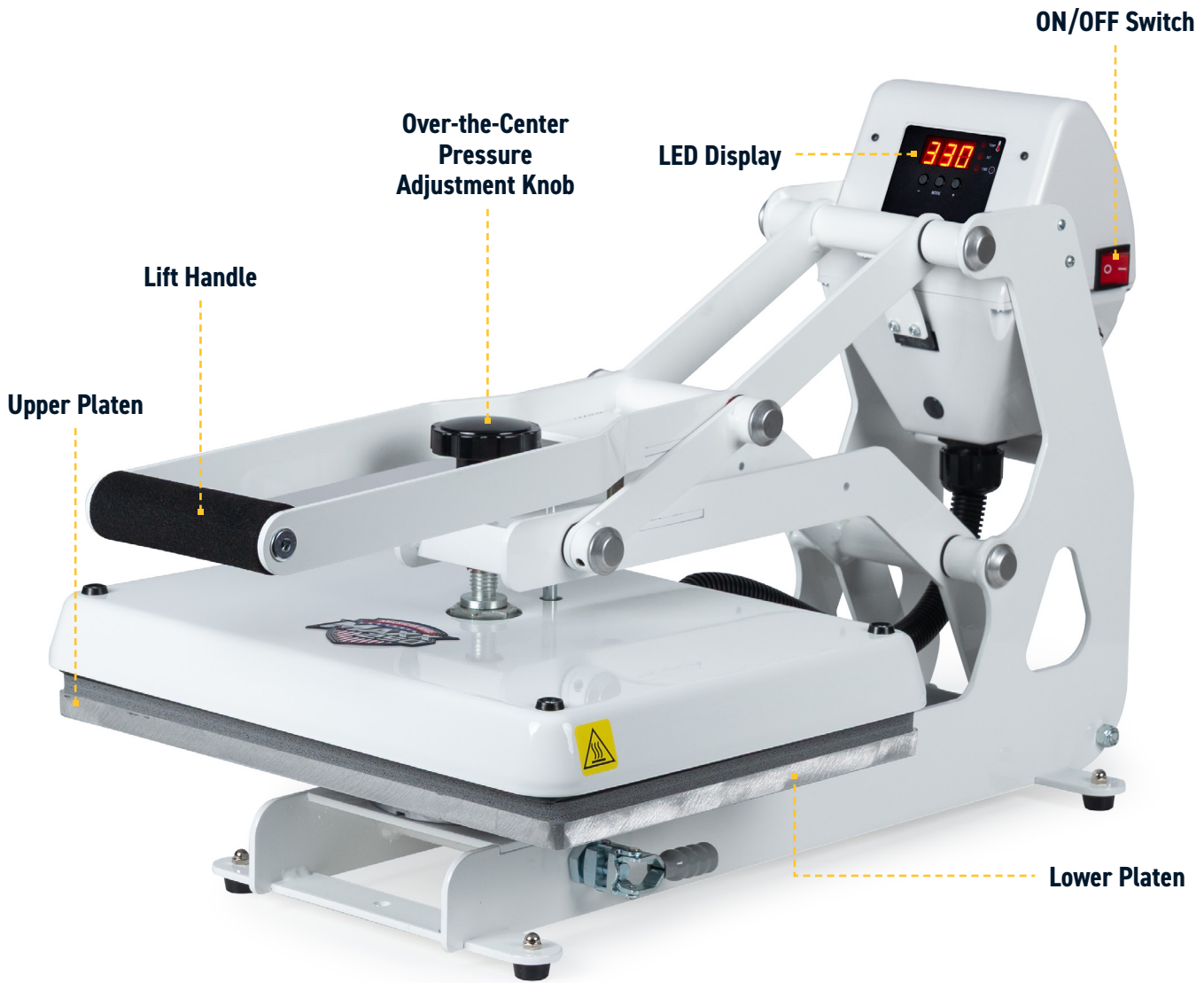

Located on the back of the press



Located under the press

Control Panel Guide

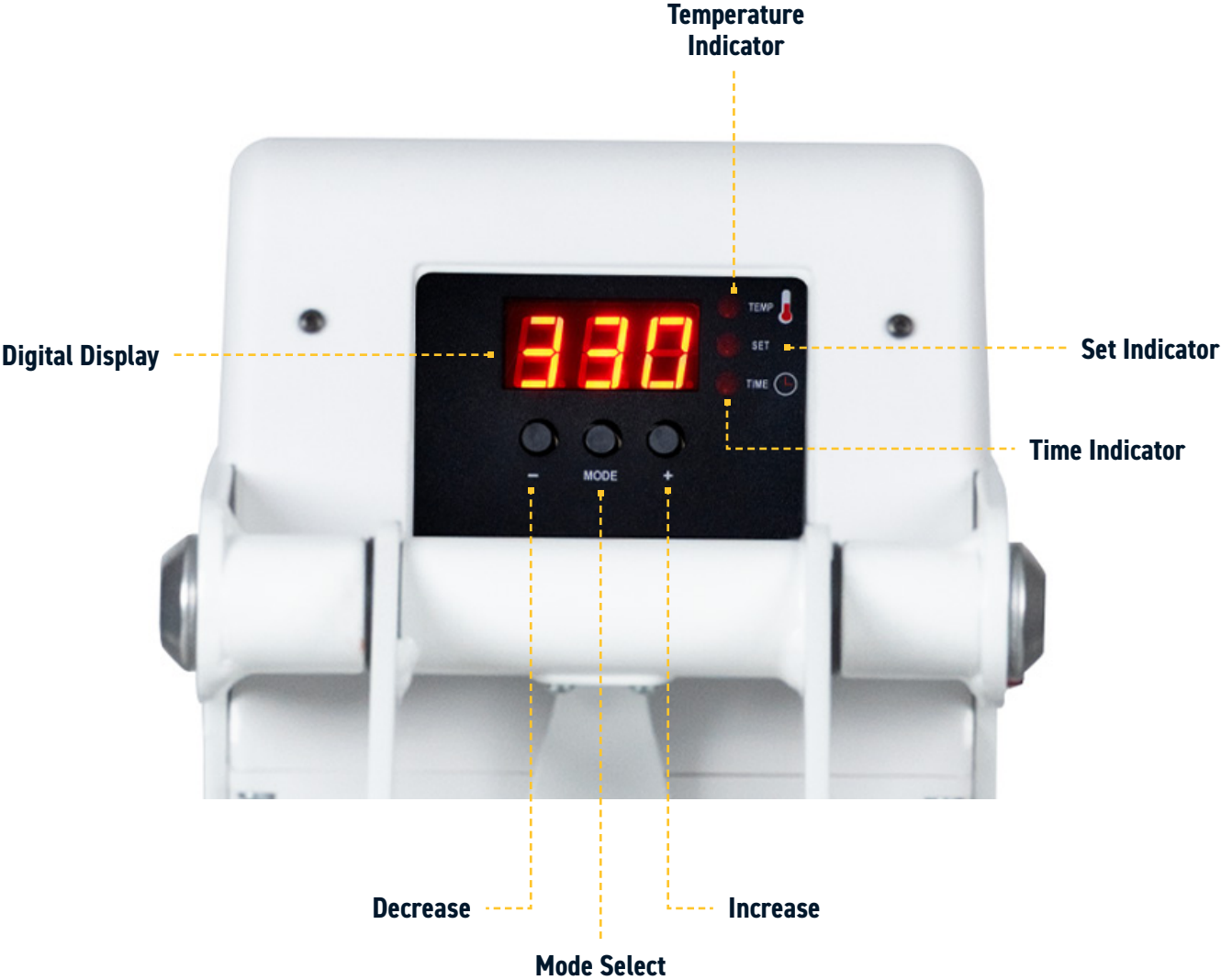

HOTRONIX® MAXX® 250 PRESS

Operating Instructions

Start Up/Shut Down



Connect the power cord into a properly grounded electrical outlet with a sufficient amperage rating.

Voltage

11" x 15"

120 volt 1000 watt presses require a full 20-amp grounded circuit for 120-volt operation.

240 volt 1000 watt presses require a full 10-amp grounded circuit for 240-volt operation.

15" x 15", 16" x 20"

120 volt 1800 watt presses require a full 20-amp grounded circuit for 120-volt operation.

240 volt 1800 watt presses require a full 10-amp grounded circuit for 240-volt operation.

Extension Cords

If used, extension cords should be as short as possible and not less than 12 gauge. Heavy duty cords are recommended.

Circuits

Circuits with less than 15 amps or that have other high demand equipment or heat presses plugged in should not be used.

***Note:** If the supply cord is damaged, it must be replaced by the manufacturer, its service agent or a similarly qualified person in order to avoid hazard. Use SJT type rated 300 V cord for replacement.*

CAUTION

Failure to follow these instructions will cause:

1. Erratic controller functions.
2. Inaccurate displays and slow heat-up.
3. The circuit breaker to disengage.



Locate the lift handle and position the heat platen in the UP (load) position.



Locate the Power ON/OFF Switch on the side of the press, then turn the Power Switch ON.

Operating Instructions

Adjusting the Temperature Adjusting the Time



Locate the LED Display on the Press.

Press the Mode Select button in the center of the Control Panel.

The (SET) and (TEMP) lights located next to the display will illuminate.

Press the (+) or (-) button to raise or lower the temperature setting.

The temperature can be set from 205°F (96°C) to 430°F (220°C). The LED Display will show changes as you make them.

Note: The temperature indicator will only display temperatures 200°F (93°C) and up.



Once you have adjusted the temperature, press the Mode Select button again to advance to the Time mode.

The [SET] and [TIME] lights will illuminate.

Adjust the time in the same manner you adjusted the temperature.

Select the desired time and push the Mode Select button again to exit.

All lights will be off and the press will return to the Print Mode.

Adjusting Pressure



The MAXX® 250 Clam Press features a patented, over-the-center pressure adjustment located in the center of the heat platen.

Turn the knob clockwise to increase pressure and counterclockwise to decrease pressure.

Remember: to allow for the thickness of your garment when adjusting the pressure.

WARNING:

Structural damage caused by excessive pressure is not covered under the limited warranty!

Printing/Pressing



Once your equipment has reached the designated temperature:

- Position the garment and design
- Lower and lock the heat platen into the PRESS position to begin the automatic timing process
- The timer will automatically count down and audibly signal you to lift the heat platen into the UP position when the print cycle is complete

Electrical Schematic

US 120V/240V Versions

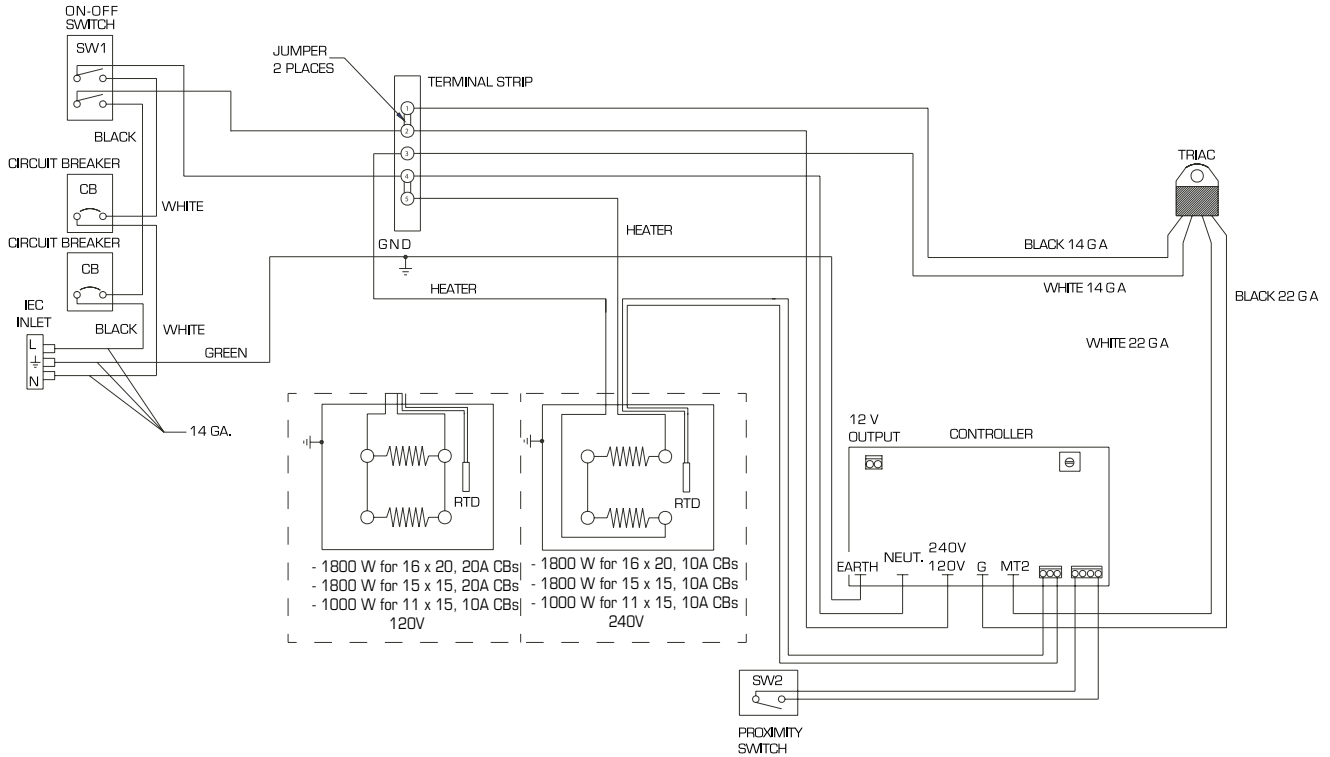

CE 230 V Version

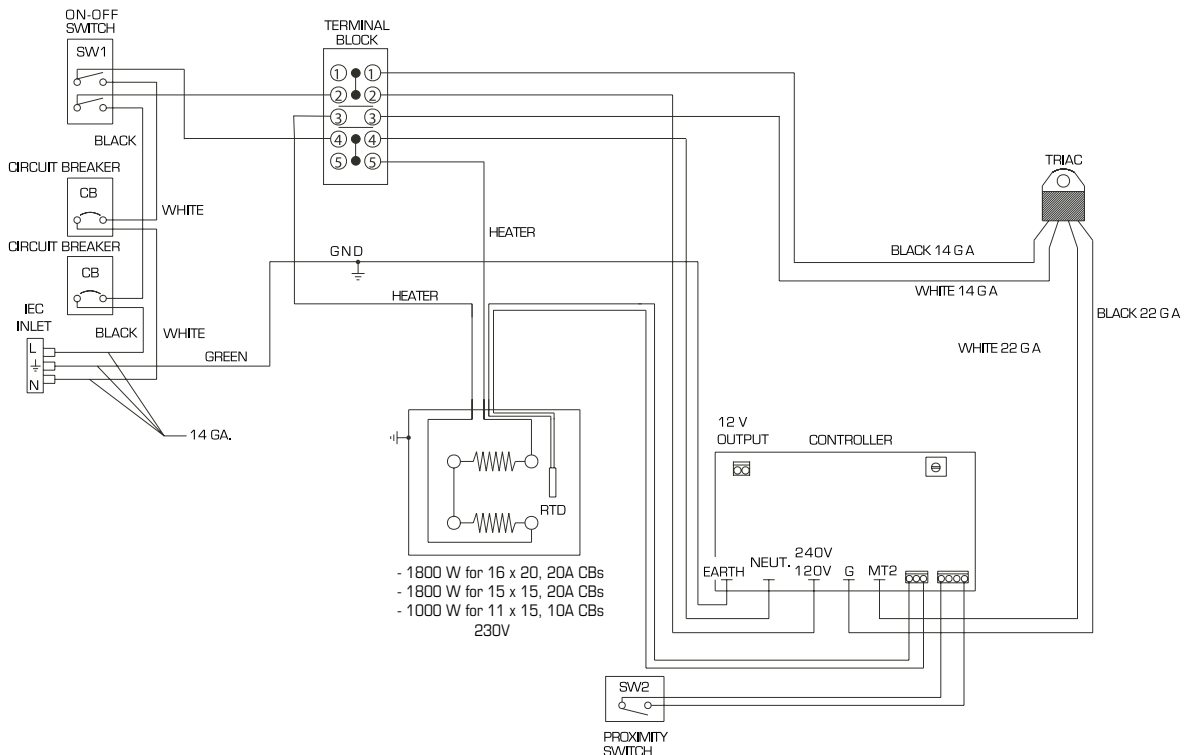

HOTRONIX[®] MAXX[®] 250 PRESS

Parts Location Guide

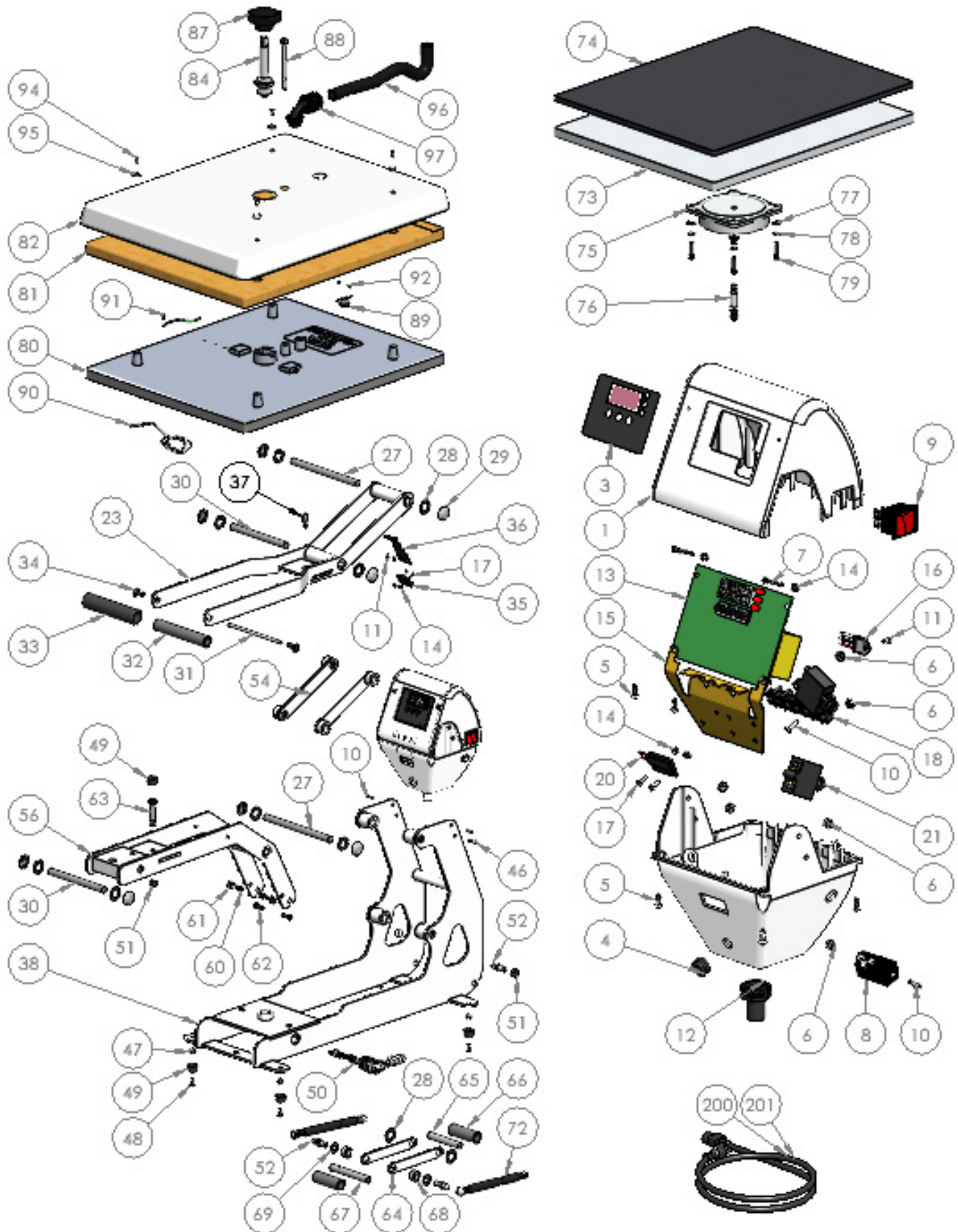

Replacement Parts List

ITEM #	PART #	DESCRIPTION	QTY
1	4-1172-B	Control Housing, MAXX	1
3	1-2018	Controller Overlay, MAXX	1
4	1-2105	Grommet, 9/32" ID 3/8" OD	2
5	3-1011-235	Screw, Sheet Metal #6 x 1/2"	6
6	2-1006-50	Nut, #6-32 Hex with Lockwasher	9
7	3-1011-130	Screw, Pan Phillips #4-40 x 1"	2
8	1-1759	Power Inlet	1
9	1-2087	Power Switch	1
10	3-1011-19	Screw, Machine #6-32 x 1/2"	7
11	3-1011-25	Screw, Machine #6-32 x 1/4"	5
12	1-1353	Conduit Fitting, 1/2" Topaz Straight Twist-On	1
13	Kit 3-6946	Controller Kit, MAXX	1
14	2-1006-51	Nut, #4-40 with Tooth Washer	8
15	2-1661	Controller Bracket, STX MAXX	1
16	1-1059	TRIAC	1
17	3-1011-22	Screw, Machine #4-40 x 3/8"	6
18	1-1290	Terminal Block, 5 Contact High Voltage	1
20	1-1211	Proximity Switch	1
21	1-1331	Circuit Breaker 20A (STX XF XRF)	1
23	KIT 3-6904	Handle Assembly MAXX	1
27	1-2094	Steel Pin 1/2" D x 6.45"	2
28	1-1048-3	Washer, 1/2" Nylon	10
29	1-1107-1	Hub Cap 1/2"	8
30	1-2093	Steel Pin, 1/2" x 5.375"	2
31	1-1042-1	All Thread Pin	1
32	1-2096	PVC Spacer 1/2 I.D. x 5"	1
33	1-1540	Foam Grip, Black	1
34	2-1006-2	JCN - NUT	2
35	1-1219	Proximity Magnet	1
36	1-2085-1	Magnet Bracket (MAXX)	1
37	3-1011-232	Shipping Bolt (Thumb Screw), 1/4"-20 x 1/2"	1
38	KIT 3-6901	Base, MAXX 16x20, 15x15, 11x15	2
46	3-1011-252	Screw, Pan Phillips #6-32 x 3/4"	1
47	3-1011-182	Acorn Nut 10-32	4
48	3-1011-164	Screw, Button Socket Head #10-32 x 1/2"	4
49	1-1256	Rubber Foot	5
50	1-2332	Quick Release Clamp, Manual Presses	1
51	2-1006-20	Nut, Hex Nylok 5/16"-18	3
52	1-1939	Ball Stud 10mm	4
54	KIT 3-6951	Pressure Link MAXX	2
56	KIT 3-6903-1	Adjustment Arm Kit, MAXX	1
60	3-1011-215	Soc HD Cap Screw 1/4-20 x 3/8"	2
61	2-1006-7	Nut, Hex 1/4"-20 Nylok	2
62	3-1011-106	Screw, Button Socket Head 1/4"-20 X 3/4"	2
63	3-1011-55	Screw, Shoulder 3/8" x 1-1/4" w/ 5/16"-18 Thread	1
64	3-6956	Bridle Links MAXX	2

ITEM #	PART #	DESCRIPTION	QTY
65	1-2091	Pin, 1/2" x 3" w/ 1/4-20 Threads	1
66	1-2098	PVC Spacer 1/2" I.D. x 2.48	2
67	1-2092	Pin, 1/2" x 3-5/8" w/ 5/16"-18 Threads	1
68	1-2114	Steel Spacer	2
69	2-1006-46	Washer, 5/16" SS	2
72	1-2243	Gas Spring 16x20 & 16x16	2
73	3-1199-1	Lower Platen 11 x 15	1
73	3-1086	Lower Platen 15 x 15	1
73	2-1029	Lower Platen, 16x20	1
74	1-1875	Silicone Pad 11 x 15 Gray	1
74	1-1473	Silicone Pad 15 x 15 Gray	1
74	1-1011	Silicone Pad 16 x 20 Gray	1
75	3-1336	Adapter Plate	1
76	1-2215	Quick Release Pin	1
77	2-1006-25	Washer, Flat 1/4" SAE	4
78	2-1006-44	Washer, Split Lock 1/4"	4
79	3-1011-191	Screw, Socket Head Cap 1/4"-20 x 1"	4
80	3-1199	Heat Platen 11 x 15	1
80	3-1320	Heat Platen 15 x 15	1
80	2-1002-3	Heat Platen 16 x 20 1800W Milled	1
81	1-2258	Insulation 11 x 15	1
81	1-2257	Insulation 15 x 15	1
81	1-2256	Insulation 16 x 20	1
82	3-1331-B	Heat Platen Cover 11 x 15 MAXX	1
82	3-1337-B	Heat Platen Cover 15 x 15 MAXX	1
82	3-1332-B	Heat Platen Cover 16 x 20 MAXX	1
84	2-1081	Adjustment Spindle	1
87	1-1012	Adjustment Knob	1
88	3-1011-63	Bolt, Hex Head 5/16-18 x 3-1/2"	1
89	1-2076	Thermostat Disc	1
90	1-1272-1	Temperature Probe	1
91	3-1011-87	Screw, SS Phillips #8-32 X 1/4"	1
92	3-1011-98	Screw, SS Sheet Metal #4 X 1/4"	2
94	3-1011-217	Screw, Flat Head Phillips #10-24 x 7/16"	4
95	1-1063	Washer, Plastic Finishing	4
96	2-1048-3	Conduit, STX & MAXX 11x15, 12"	1
96	2-1048-3	Conduit, STX & MAXX 20/16/15, 12"	1
97	1-1940	Conduit Fitting, 1/2" Elbow	1
200	2-1671	120V Locking Power Cord	1
201	1-2186	220V Power Cord	1
202	2-1672	230V European Locking Power Cord	1
207	1-1068	Heater Wire (Not Shown)	1

CONTACT US

STAHL'S Hotronix®

One Industrial Park
Carmichaels, PA 15320
U.S.A.

Technical Support

hotronix.com/support

Customer Service

customerservice@hotronix.com

Replacement Parts

hotronix.com/locationspart

Web

hotronix.com



This document includes multiple trademarks and describes equipment covered by many patents that are owned by GroupeSTAHL and/or its subsidiaries. GroupeSTAHL enforces its rights to protect these intellectual properties. ©2026